

12" Velocity Hinged Knee (Anterior Closure)

Warnings and Instructions: Review carefully, proper application is required

⚠ Warning: This device will not prevent or eliminate risk of injury. Do Not Overtighten. If swelling, pain, skin irritation, or an unusual reaction occurs, discontinue use immediately and consult your medical professional. This device should not be worn by persons with known allergies to neoprene.

Care: Hand wash using mild soap. Rinse thoroughly. Air dry only. Do not tumble dry.

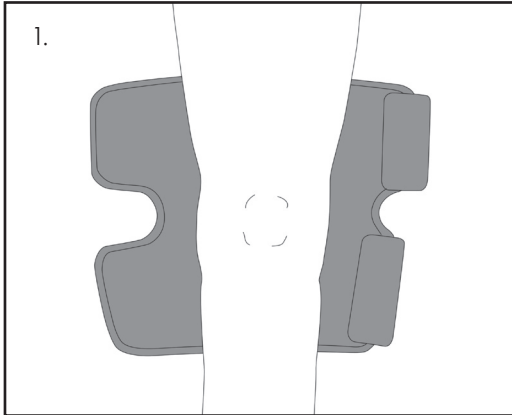

1. Center brace on back of leg.

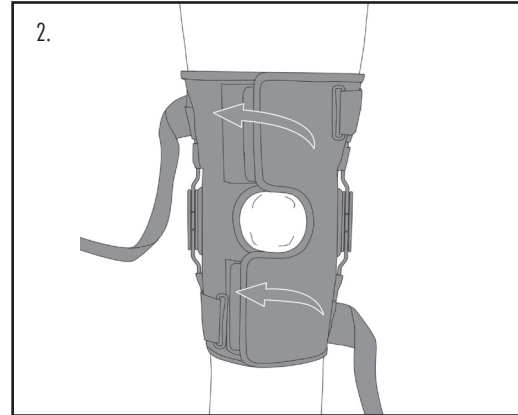

2. Pull upper and lower flaps and fasten.

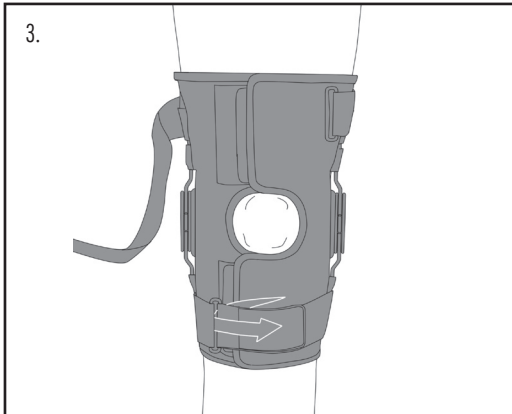

3. Pull lower strap through loop lock and fasten.

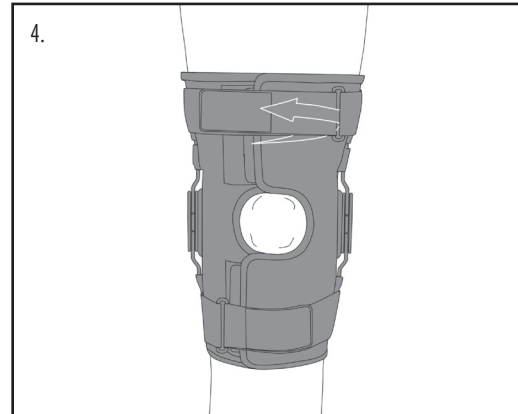

4. Pull upper strap through loop lock and fasten.

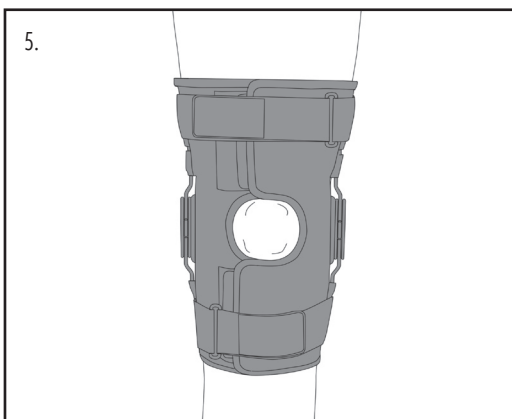

5. Finished application.

Range of Motion Hinge Stop Application

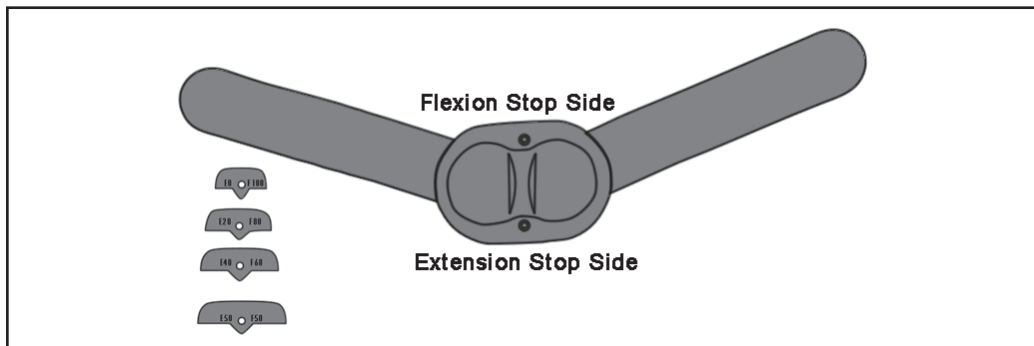

Extension stops are available in 10 degree increments from 0 to 50 degrees. Flexion stops are available in 10 degree increments from 50 to 100 degrees. Each stop has two numbers on the front for the degree of flexion (F) or the degree of extension (E) based on which side of the hinge the stop is used.

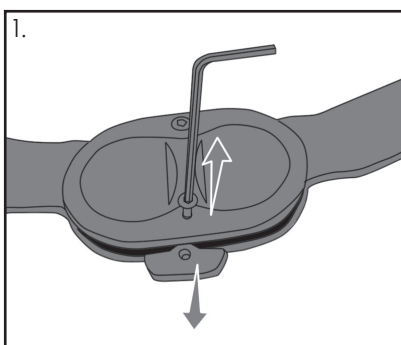

1. Use the included hex wrench to remove the existing hinge stops by removing the screws on both the extension stop side and flexion stop side of the hinge cover.

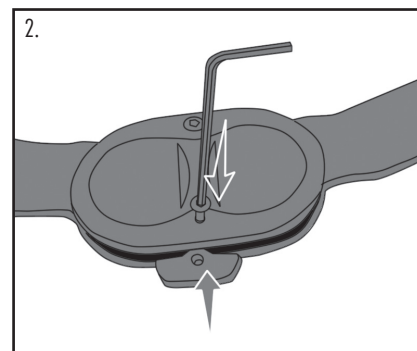

2. Choose the stop with the desired degrees of extension and install it on the extension stop side of the hinge. Be careful not to overtighten the screw and strip the hole.

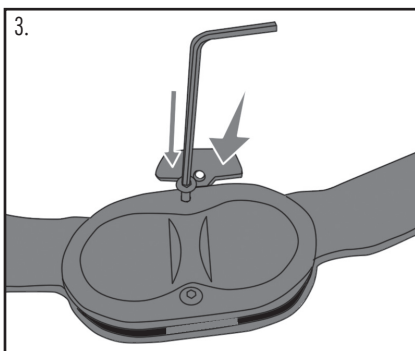

3. Choose the stop with the desired degrees of flexion and install it on the flexion stop side of the hinge. Be careful not to overtighten the screw and strip the hole.

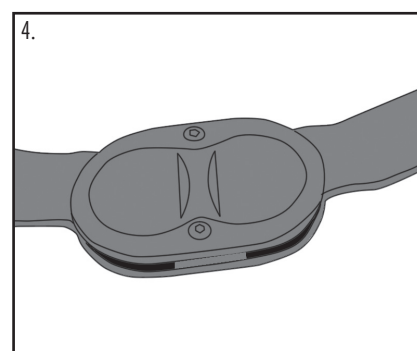

4. Completed application.
Note: Set both the medial and lateral hinges to the same flexion and extension.